

ecopietra

---

# pietre di paragone

PIETRE NATIVE



CASALGRANDE  
PADANA

THE GREEN WAY TO PAVE





FLOOR: gré bianco, gré bianco 20 mm grip cm 60x60 - 23<sup>5/8</sup>"x23<sup>5/8</sup>"

**pietre di paragone**

PIETRE NATIVE



grè grigio

COLORI | COLOURS | COULEURS | FARBEN



gré grigio



gré bianco



gré nero



luni











grigio tao





pietra del cardoso

**FORMATI SPESSORI SUPERFICI | SIZES THICKNESSES SURFACES | FORMATS EPAISSEURS SURFACES | FORMATE SURFACES OBERFLÄCHEN**

Caratteristiche tecniche Pietre Native a pagina: Pietre Native Technical features on page:  
 Caractéristiques techniques Pietre Native à la page : Pietre Native Technische Eigenschaften auf Seite: **525**

								
Formati Sizes Formats Formate	<b>cm 30x60</b> 11 <sup>3/4</sup> "x23 <sup>5/8</sup> "	<b>cm 60x60</b> 23 <sup>5/8</sup> "x23 <sup>5/8</sup> "	<b>cm 60x120</b> 23 <sup>5/8</sup> "x47 <sup>1/4</sup> "	<b>cm 90x90</b> 35 <sup>3/8</sup> "x35 <sup>3/8</sup> "	<b>cm 120x120</b> 47 <sup>1/4</sup> "x47 <sup>1/4</sup> "	<b>cm 60x120</b> 23 <sup>5/8</sup> "x47 <sup>1/4</sup> "	<b>cm 120x120</b> 47 <sup>1/4</sup> "x47 <sup>1/4</sup> "	<b>cm 120x278</b> 47 <sup>1/4</sup> "x109 <sup>1/2</sup> "
Spessori Thicknesses Epaisseurs Stärken	mm 9	mm 9	mm 9	mm 9	mm 9	mm 6	mm 6	mm 6
Gré Bianco	● ●	● ●	● ● *		●	●	●	●
Gré Grigio	● ●	● ●	● ● *		●	●	●	●
Gré Nero	● ●	● ●	● ● *		●			
Grigio Tao		● ●	● ● *	●	●	●	●	●
Luni	● ●	● ●	● ● *	●				
Pietra del Cardoso		● ●	● ● *	●	●	●	●	●

			
Formati Sizes Formats Formate	<b>cm 160x320**</b> 63"x126"	<b>cm 60x60</b> 23 <sup>5/8</sup> "x23 <sup>5/8</sup> "	<b>cm 60x120</b> 23 <sup>5/8</sup> "x47 <sup>1/4</sup> "
Spessori Thicknesses Epaisseurs Stärken	mm 12	mm 20	mm 20
Gré Bianco	●	●	●
Gré Grigio	●	●	●
Gré Nero			
Grigio Tao	●		
Luni			
Pietra del Cardoso	●		



- Naturale Matt Naturelle Matt **R10 A+B \*\*\***
- Grip **R11 A+B+C PTV > 36**

Vedi pagina: See page: Voir page : Siehe Seite: **533**

Rettificate monocalibro Rectified monocaliber Rectifiés calibre unique Rektifiziert Monokaliber





\* Su richiesta On request Sur demande Auf Anfrage können

\*\* Non rettificato Not rectified Non rectifié Nicht rektifizierle

\*\*\* Non idonea per destinazione d'uso spiaggia piscina e/o spogliatoi Not suitable for use for pool decks and/or changing rooms  
 Ne convient pas pour une destination d'usage comme plage de piscine et / ou vestiaire Nicht geeignet für Schwimmbeckenränder und/oder Umkleidekabinen

● BS 7976-2:2002 + A1:2013\_Valore indicativo, superficie bagnata ed asciutta Approx value, wet and dry surface Valeur approximative, surface humide et sèche Näherungswert, nasse und trockene Oberfläche

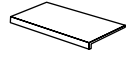
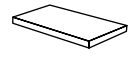
PEZZI SPECIALI | TRIMS | ACCESSOIRES | FORMSTÜCKE

				
<b>Battiscopa</b> Bullnose Plinthe à bord arrondi Stehsockel	<b>Gradino</b> Step tread Nez de marche Stufenplatte	<b>Gradone (assemblato)</b>	<b>Angolare (assemblato)</b>	<b>Terminale</b> Pezzo unico pressato Pièce unique pressée Pressed single piece Gepresstes Einzelsück
<b>cm 9x60</b> 3 <sup>1/2</sup> "x23 <sup>5/8</sup> "	<b>cm 30x60</b> 11 <sup>3/4</sup> "x23 <sup>5/8</sup> "	<b>cm 120x33x4</b> 47 <sup>1/4</sup> "x13"x1 <sup>5/8</sup> "	<b>cm 120x33x4</b> 47 <sup>1/4</sup> "x13"x1 <sup>5/8</sup> "	<b>cm 15x30x3,5</b> 5 <sup>7/8</sup> "x11 <sup>3/4</sup> "x1 <sup>3/8</sup> "
<b>cm 9x90</b> 3 <sup>1/2</sup> "x35 <sup>3/8</sup> "	<b>cm 30x120</b> 11 <sup>3/4</sup> "x47 <sup>1/4</sup> "			

DECORI | DECORS | DÉCORS | DEKORE

mosaico 6x6 ■

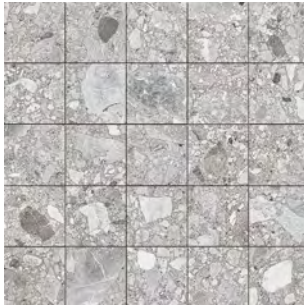

**cm 30x30** - 11<sup>3/4</sup>"x11<sup>3/4</sup>"  
tessera **cm 6x6** - 2<sup>3/8</sup>"x2<sup>3/8</sup>"  
su rete on net sur trame auf Netz

mosaico 10x10 ■

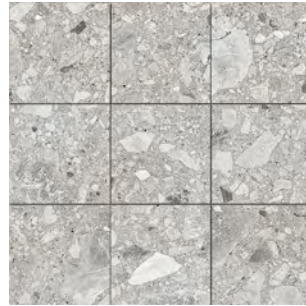

**cm 30x30** - 11<sup>3/4</sup>"x11<sup>3/4</sup>"  
tessera **cm 10x10** - 4"x4"  
su rete on net sur trame auf Netz

■ Disponibile in tutti i colori della collezione, superficie naturale e grip  
Available in all the colours of the collection, matt and grip surface  
Disponible dans toutes les couleurs de la collection, surface naturelle et grip  
Verfügbar in allen Farben, matte und grip Oberfläche

# PIETRE DI PARAGONE

PIETRE NATIVE

Gres porcellanato Fully vitrified porcelain

Grès cerame vitrifié Feinsteinzeug

CARATTERISTICHE TECNICHE TECHNICAL FEATURES

CARACTÉRISTIQUES TECHNIQUES TECHNISCHE EIGENSCHAFTEN













CASALGRANDE  
PADANA  
THE GREEN WAY TO PAVE



UPEC\*\*



	norma standards norme Norm	risultato prova* test results* resultats des essais* Ergebnisse*
 classificazione prodotto product classification classement Klassifizierung	UNI EN 14411-G ISO 13006	gruppo Bla completamente greificato group Bla fully vitrified group Bla grès cérame fin Gruppe Bla Feinsteinzeug
 caratteristiche dimensionali e d'aspetto dimensional and surface quality caractéristiques de la surface Oberflächenqualität	UNI EN ISO 10545-2	tolleranze minime nella 1ª scelta very low tolerance des tolérances minimales en 1er choix Entspricht Normen
 assorbimento di acqua water absorption absorption d'eau Wasseraufnahme	UNI EN ISO 10545-3	< 0,1%
 resistenza alla flessione flexural strength résistance à la flexion Biegezugfestigkeit	UNI EN ISO 10545-4	45 N/mm <sup>2</sup>
 resistenza al gelo frost resistance résistance au gel Frostwiderstandsfähigkeit	qualsiasi norma all standards toute norme alle normen	garantita guaranteed garantie Garantiert
 resistenza attacco chimico (esclusione acido fluoridrico) resistance to acids and alkalis (with the exception of hydrofluoric acid) résistance à l'attaque chimique (exclusion de l'acide fluorhydrique) Säure und Laugen Beständigkeit (mit Ausnahme von Fluorwasserstoff)	UNI EN ISO 10545-13	A
 resistenza usura e abrasione wear and abrasion resistance résistance à l'usure et abrasion Abriebhärte	UNI EN ISO 10545-6	≤ 150 mm <sup>3</sup>
 dilatazione termica lineare linear thermal expansion coefficient linéaire de dilatation thermique Lineare Wärmeausdehnung	UNI EN ISO 10545-8	6 x 10 <sup>-6</sup>
 resistenza alle macchie stain resistance résistance aux taches Fleckenfestigkeit	UNI EN ISO 10545-14	4 - 5 garantita guaranteed garantie Garantiert
 resistenza alla scivolosità (Superficie Naturale) slip resistance (Matt surface) résistance au glissement (Surface naturelle) Trittsicherheit (Natur Oberflächen)	DIN EN 16165 ANNEX B - ANNEX A  D.M. N° 236 DEL 14.06.89 METODO B.C.R.  BS 7976-2:2002 + A1:2013	Naturale Matt Naturelle Matt <b>R10 A+B*</b> Grip <b>R11 A+B+C</b>  valore $\mu > 0,40$  Grip <b>PTV &gt; 36***</b>
 resistenza dei colori alla luce colour resistance to sunlight exposure résistance de la couleur à la lumière Unveränderlichkeit der Farben wenn Strahlung zugesetzt wird	DIN 51094	nessuna variazione no change of colours couleurs inchangées Keinerlei Farbänderung

\* valore indicativo approx value donnée approximative Ungefähre Werte

\*\* si rimanda all'elenco prodotti UPEC ufficiale, consultabile sul sito: please see the official UPEC product list:

veuillez consulter la liste officielle produits UPEC: siehe die offizielle UPEC-Produktliste auf der Website: <http://evaluation.cstb.fr>

\*\*\* Valore indicativo, superficie bagnata ed asciutta Approx value, wet and dry surface Valeur approximative, surface humide et sèche Näherungswert, nasse und trockene Oberfläche

• Non idonea per destinazione d'uso spiaggia piscina e/o spogliatoi Not suitable for use for pool decks and/or changing rooms

Ne convient pas pour une destination d'usage comme plage de piscine et / ou vestiaire Nicht geeignet für Schwimmbeckenränder und/oder Umkleidekabinen

Al pari dei materiali naturali di riferimento, l'aspetto estetico, la differenza di tono e le venature possono essere diverse da piastrella a piastrella. Per una corretta comprensione della variabilità del prodotto è consigliabile prendere visione delle immagini a tutto ambiente sul catalogo di collezione, sul nostro sito all'indirizzo [www.casalgrandepadana.it](http://www.casalgrandepadana.it) o chiedere maggiori informazioni ai nostri concessionari.

Just like the natural materials they are inspired by, the aesthetics, colouration and veining of the tiles can differ. To properly gauge the suitability of a product, we advise that you view the full-space photos that you can find in our collection catalogue and on our website at [www.casalgrandepadana.com](http://www.casalgrandepadana.com). Alternatively, please ask a reseller for more information.

Tout comme pour les matières naturelles de référence, la différence de tonalité, les veines ainsi que l'aspect esthétique peuvent varier d'une dalle à l'autre. Pour bien comprendre la variabilité du produit, il est conseillé de consulter les images d'ambiance présentes sur le catalogue de la collection, sur notre site à l'adresse [www.casalgrandepadana.fr](http://www.casalgrandepadana.fr) ou de demander plus d'informations à nos concessionnaires.

Wie bei den als Vorbild dienenden Naturmaterialien können sich auch hier das ästhetische Erscheinungsbild, der Farbtonunterschied und die Maserung von Fliese zu Fliese unterscheiden. Um die Variabilität des Produkts besser zu verstehen, raten wir Ihnen, die Bilder mit ausgestatteten Räumen im Kollektionskatalog auf unserer Website [www.casalgrandepadana.de](http://www.casalgrandepadana.de) zu konsultieren. Weitere Informationen können Sie auch bei unseren Vertragshändlern erhalten.





**CASALGRANDE  
PADANA**  
THE GREEN WAY TO PAVE

via Statale 467, n. 73 - 42013 Casalgrande (Re) Italy  
tel + 39 0522 9901 - fax + 39 0522 996121  
info@casalgrandepadana.it - www.casalgrandepadana.com

